

Service BULLETIN

APPLICABLE TO 60427, 64049, 64348
& 64349 NOZZLES & 60129-1, 44646 &
47013 HOSE END CONTROL VALVES

SB3480601A
Nov. 1, 1997



carter ground fueling

REVISED FROM AUGUST 1 ISSUE! (Changes to Figure 1 and bold type, page 4) VARIOUS CHANGES MADE TO CARTER NOZZLES / HOSE END CONTROL VALVES

Several changes and additional options to Carter Nozzles and Hose End Control Valves have been put into effect or offered for sale in the past months. This bulletin is being issued to summarize these changes.

→ Poppet - Shroud Assembly 210593 – All Nozzles:

The poppet used on all of the applicable nozzles (listed above) consists of a die cast aluminum poppet to which originally a stamped aluminum sheet metal shroud was affixed by press fitting it to the poppet. The shroud was designed to provide a smooth flow path, thereby reducing the pressure loss across the nozzle. The shroud serves no other purpose.

In 1992, some months after introducing this new poppet design, which is used on all Carter current production nozzles, a shroud was reported to have come off of its poppet and was found loose on the nozzle shaft. At that time we investigated the assembly method used and tightened quality control on the assembly. It was soon discovered that no matter what methods were used the flow forces due to turbulence in the poppet area were sufficient to cause the shroud to come loose, in time. A more permanent fix was then put into place. An internal star snap ring (circlip) was pressed over the diameter of the poppet that surrounded the threaded portion in which the shaft is assembled. This stainless steel ring provided a secure fastening of the shroud into place.

In Service Bulletin SB427-9 it was pointed out that any nozzle user who found a loose shroud should:

1. Remove the shroud and put the nozzle back into service without it.
2. Turn the shroud into your Carter distributor who was authorized to provide you with a complete poppet/shroud assembly, 210593, at no charge to replace the damaged one.

With the addition of the ring to the assembly, no further reports have been received of any problems. In the normal inspection of the nozzle at overhaul should one come upon a poppet assembly that does not have the ring, contact your distributor and a ring will be furnished at no charge. The ring number is 5115-75-H-015. Refer to the figure on the right for detailed assembly instructions.

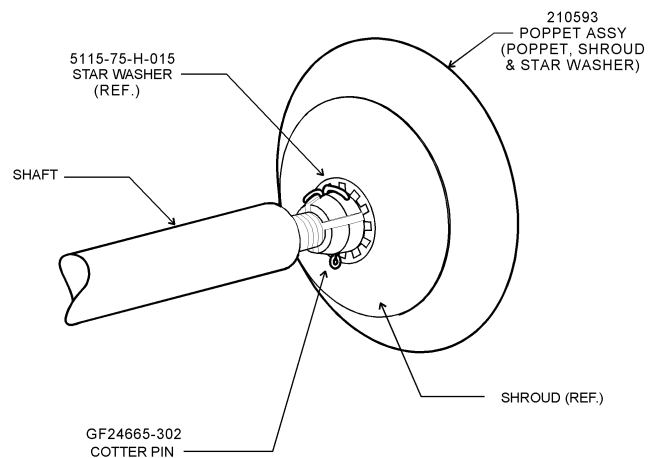

→ 61154 Dry Break Male Half Adapter Seal – All nozzles with this dry break disconnect:

The seal used between the mating halves of the 61154 Dry Break Quick Disconnect was originally a specially designed “chevron” type seal that was loaded by a smaller internal o-ring. This seal, part number 209988, provided good sealing

characteristics with very low friction to make the unit an effective swivel and make it easier to disconnect the unit to inspect the strainer. After several years of service reports started coming in of leakage past this seal under two conditions:

1. Low pressure, mainly head pressure when the unit was in a non-functional mode.
2. Side load condition, again at lower pressures.

Effort was put into solving the problem and several designs were tested in the Carter facility and once a successful unit was found several field tests were instigated to be sure the new seal would work. The current seal is a special material o-ring and is part number 220709-232. This new o-ring has been in production for several months now and if the old part number is ordered, the new one will be shipped automatically. All new seal kits for the unit (or for the complete nozzle including the dry break) will also be shipped with the new o-ring. The Service Manual, SM61154, will be changed at the next printing.

➔ Drag Rings – All Nozzles as noted herein:

The 60427 and 64348 Nozzles are now offered with a sacrificial “drag” ring as an option when a Hose End Control Valve is provided (options F3, F4 or F5). These rings made of tough polyurethane will easily pay for themselves in saving wear and tear on the HECV body and other parts of the nozzle. Dragging is a fact of life with this equipment. Hence it make sense to wear out a part that is far less expensive than the HECV body and it is far safer than a potential spill due to weakened wall thickness. These rings are available as spare parts and as options as shown below.

NOZZLE	OPTION LETTER WHEN PURCHASED AS A PART OF THE NOZZLE	PART NUMBER AS A SPARE PART
60427 (Only with F3, F4, or F5 Options)	H	220460
64348 (Only with F3, F4, or F5 Options)	H	210641

These rings are in stock for immediate delivery as spares.

Other manufacturers and distributors provide drag rings for Carter products. The ones offered by or through Warner Lewis, our European distributor, are identical to the ones we provide. The ones offered by manufacturers not authorized by Carter have not been tested by Carter and can not be sanctioned by us.

➔ Operating Lever - 64348, 64049 and 64349 only:

The operating lever, 220270, on the 64349 and 64049 has been changed to a new shape and orientation. The new style handle, 220561, is now standard on the 64049 and 64348 and as option “G” on the 64349.

The four screws that hold the 220270 into place in the nozzle have had a past history of coming loose in service. After investigation, it was found that the Heli-coil inserts within the lever were weakening the self-locking patches used on the screws. The Heli-coil inserts were used only as a stop gap measure on the 64348/64349/64049 Nozzles until tests could be run to prove that the strength of the thread cut directly into the lever was sufficient to not need inserts. This testing was conducted and the inserts removed from the 220270 Lever. When the 220270 levers without the inserts were introduced, they were identified with an “X” either stamped or cast on the exterior of the part. No inserts were ever used on the newer 220561 and to our knowledge, no screws have been found loose on those levers without inserts.

In an effort to “be sure” we have designed and will be putting a new handle design into effect within the next few weeks. This new design will remove the four screws from the nozzle and replace them with a single screw installed from the outside. The new lever will consist of a two piece affair that is “geared” together, the handle part being replaceable from the outside. The single screw, locked by a Heli-coil insert, will only be used to hold the two parts together and the gear teeth on the two mating parts will take the torque loading associated with the opening and closing of the nozzle. The four screws previously used were also used as the stop for the poppet. This action tended to loosen the screws. The stop will now be an integral cast boss on the new crank furnished as a part of the new handle kit.

In the future, when either the 220270 or 220561 Levers are ordered Kit KD64348-12 will be furnished. This kit will provide all parts needed to install the new lever design on all of the affected nozzles. If any customer is having problems with the original 220270 Levers **with Heli-coil inserts**, they can exchange these troublesome handles, regardless of condition, at a Carter distributor, for the new kit. Installation instructions will be included in the kit.

➔ Nozzle Nose Seals – All current Carter nozzles:

There have been complaints from the field, over the years, about the nose seals used on Carter nozzles “reverting” to a tar or sticky gum material. The nose seal has to be rugged and tough to withstand the mating action of the nozzle. The only material, that will resist cutting from being installed on worn and sharp adapters, that has been found in the many years that the 60427/64348 and other Carter nozzles have been in service is one called polyurethane. Polyurethane is a very tough material but it has a limited shelf/usage life when stored under certain conditions. Long periods of relative high temperatures and humidity will cause it to revert to a gummy substance and make it unusable. Normal nozzle use, where the nozzle is wetted with fuel several times a day, lengthens the time the nose seal can be used without experiencing the reversion process. However, if the nozzle is left to set dry in temperatures at or above 90°F (30°C) and in over 75% humidity (combined conditions) reversion is likely. If you are going to store nose seals (209029) (or circular grips, 207816, as well) we recommend that they be kept in conditions less than those listed above while in storage. (Our major domestic competitor uses the same material and in fact the same supplier makes both of our nose seals). A word about warranties on our equipment as it relates to nose seals. We warrant these parts for one year from shipment. Reversion will not occur in that time frame. If proper storage/usage is observed, reversion will not occur for several years. Complaints of reversion on nozzles/seals of over five years in storage, some well over 8 years, or use have been made and these are well outside of our warranty and a reasonable life time and will not be honored as a warranty claim. All service manuals recommend replacement of such seals on an annual basis. We have seen them last well over two years under constant use.

➔ Hose End Control Valve – 60129-1, 44646 & 47013 HECV’s:

Several changes have been made to these units, some previously noted in service bulletins. This will outline these various changes in one bulletin.

❑ External Leakage from Breather Port – Although some minor leakage, mostly wetting or weepage, from the breather port has been present for the lifetime of these devices, the need to meet more stringent environmental requirements lead to requests by some customers to reduce this leakage. To understand the problem one has to understand that the device depends upon an atmospheric reference chamber on one side of the operating piston chamber. Friction of the seal between this air reference chamber and the fuel side of the piston has to be minimized to assure proper operation of the pressure control function of the device. Low friction requirements necessitates the need to use some form of Teflon as the sealing devices. Teflon is a difficult seal material to use and to expect zero leakage, hence the weepage over the years.

In our efforts to reduce the leakage past the seals the friction between the piston, 24096, and the seal, 24085, was reduced by improving the surface finish of both the piston and the seal. Various lapping techniques during assembly were also tried and eventually discarded as a primary method of reducing friction. A “dual” seal design was introduced and became standard. Field trials of the dual seal concept and the better surface finish of the mating parts reflected an improvement in the external leakage results. These changes were then

incorporated into the production design of the units. The dual seal design is an easy change in that the HECV already had the necessary room for the installation. Old units had a single seal held in place by two spacer rings. The newer units now have another seal replacing one of the spacers. The new installation is shown in the figure on the previous page.

THE WRONG FIGURE WAS INADVERTENTLY PUBLISHED IN THE AUG. 1 ISSUE.

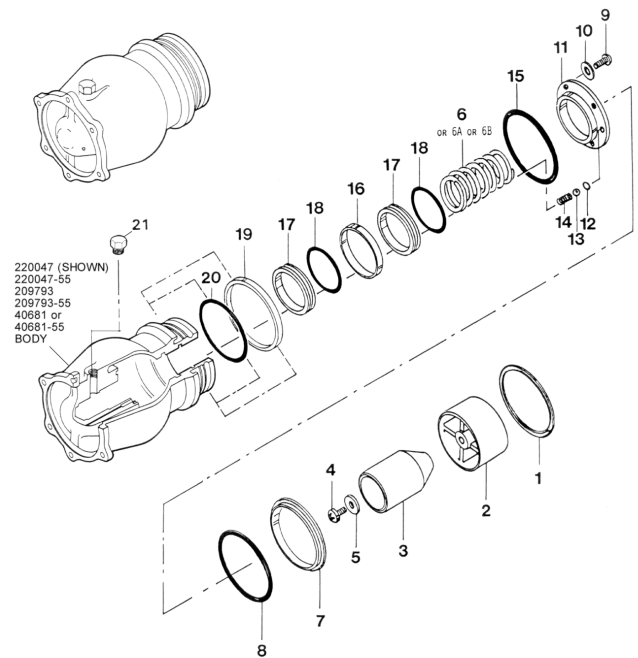

FIGURE 1

All maintenance and overhaul kits have been changed to include all the parts needed to install the dual seal configuration, including a new plastic spacer used to better support and separate the two seals. Shipments made from Carter for several months have included such parts. If you do not use kits to do your overhaul work simply order two each of the Teflon seals, 24085, and two of the MS29513-126 O-rings used with the seals. The new spacer, 24059 (same part number), can also be ordered separately but the existing one will suffice.

☐ Chatter Problem – All HECV’s

A direct result of reducing the friction mentioned in the paragraphs above was cases of isolated chatter which can damage the pistons and cause poor performance. This after exhaustive testing, both in the laboratory and in field testing, was only caused on units subjected to high flow rates, namely near or over 450-500 gpm. During the testing, it was determined that the cause was related to the shape of the inner body of the larger piston, 23889. The shape of the piston had been changed in the early 1980’s with no related problems. Revising the shape of this part solved the chattering problem even with the newer lower friction sealing. **The change involved reshaping the inner body of the large piston, 23889, to reduce the area exposed on the inlet side to approximately 0.19” (5 mm) diameter. This was accomplished on some units by machining the inner portion of the piston to reduce the material between the webs. On later units the casting was changed.** Just because your HECV piston has the old shape, it does not mean that you have a problem. As we pointed out above, the change was made over 15 years ago and no problems were apparent until the reduced friction seals were introduced and even then the flow rate had to be quite high.

If you have been experiencing a chatter problem, seen damage to the end of the smaller piston or damage to the 23890 Retainer (center hole tends to become square shaped) then return the damaged parts to a Carter distributor and he will provide a replacement kit free of charge. The following kits are available:

HOSE END CONTROL VALVE PART NO.	KIT PART NUMBER NEEDED	
	WITHOUT RETAINER	WITH RETAINER
60129-1	KD23889-1	KD23889-1-2
44646	KD23889-3	KD23889-2-3
47013	KD23889-4	KD23889-2-4

☐ Breathers – All HECV’s (some of this is a summary of previously issued information):

The original breather used in the HECV consisted of a plug type part with a hole through it in which a 100-mesh screen was held in place by a snap ring or circlip. This breather, although in service for over 20 years, did permit fuel, that had leaked into the air chamber that was being vented by the breather, to be expelled from the breather directly onto an operator. A change in the design was incorporated that had a blind hole that did not exit axially to the breather. Side holes were drilled on an angle to direct any flow away from the operator. The screen was replaced by a sintered bronze filter element located in the hole. It was not visible from the outside. Some customers expressed concern that the holes, which were directed into the port in which the breather was mounted, would offer too much resistance to fuel being pumped from the chamber during a surge operation. Tests confirmed otherwise. The angled holes were changed, however, to a “straight out” the side orientation. At a later date our supplier developed a problem in keeping the sintered bronze element in place. We then changed the design to once more utilize a screen that was permanently held in the hole. This is the current configuration. Through out the entire change process the part number, 40427, has remained the same. If for any reason you have problems with any of the older versions, let your Carter distributor know and we will provide a free replacement.